

KMTC-S-SD-0412



Resistant to strong alkali & acid

Product Description	Chemical Composition: Modified PES Membrane Type: UF Membrane Module Structure: SS304 housing, 18 pcs membrane tubes with 1/2 inch diameter Application: Caustic recovery, waste lye recovery
----------------------------	--

Product Details	KPN	Module Model	Element Model	Membrane Area	
				ft ²	m ²
	5130001	KMTC-S-SD-0412	AR-E30C	26.8	2.5

Operating & Design Information	Normal operation pressure:	4-6 bar
	Max operating temperature:	60°C *
	Max pressure on permeate side:	0.2 bar
	Max cleaning temperature:	60°C *
	pH scope—continuous operating	0-14 **
	pH scope—CIP cleaning	0-14 **

* When the temperature exceeds 50°C, please refer to “Membrane operating parameters”

** Membrane permeate tube is made from stainless steel, please prevent from contacting with corrosive acid.

Standard Dimension

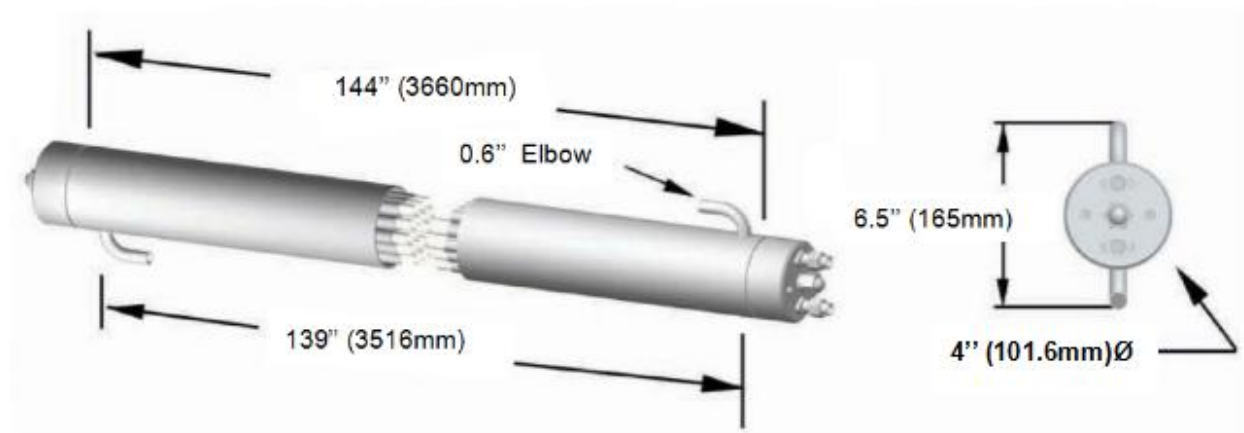

Resistant to strong alkali & acid

Membrane characteristics:

Tubular membranes own superior resistance to alkali and acid.

Operating conditions:

- **Operating pressure:** Max operating pressure on membrane is 220psi (15bar). Actual operating pressure varies according to system feed water, feed water quality, recovery rate, system temperature.
- **Max permitted backflush pressure:** 3psi (0.2bar).
- **Pressure drop:** Max pressure drop on single membrane is 65psi (4.5bar). Actual pressure drop depends on feed liquid's cross flow speed, temperature, density and viscosity.
- **Temperature:** Max operating temperature is 60°C. As to suggested temperature and pressure, please refer to "Membrane operating parameters".
- **pH:** pH scope in continuous operation is 0-14. Permeate tube is made from stainless steel, please prevent from contacting with corrosive acid.
- **Cleaning and dialysis water quality:**
Turbidity: Max inflow turbidity is 1 NTU.
Guidance: More detailed guidelines, please contact Kaimi Research & Development center.
- **Resistant to chlorine and chemical reagent:**
>> When pH ≥10, membrane is resistant to 200ppm chlorine. Membrane performance will be affected by high density chlorine or lower pH.
>> Membrane can not contact with organic solvent, like alcohol and acetone etc.
- **Water inflow:** The recommending water inflow is 15L/min. Actual water inflow depends on membrane flux, inlet characteristics, fouling tendency and system design.
- **Membrane operating parameters:** It's important to observe relation of pressure and temperature (showed as below) to prevent unrecoverable degradation of membrane compaction and performance.

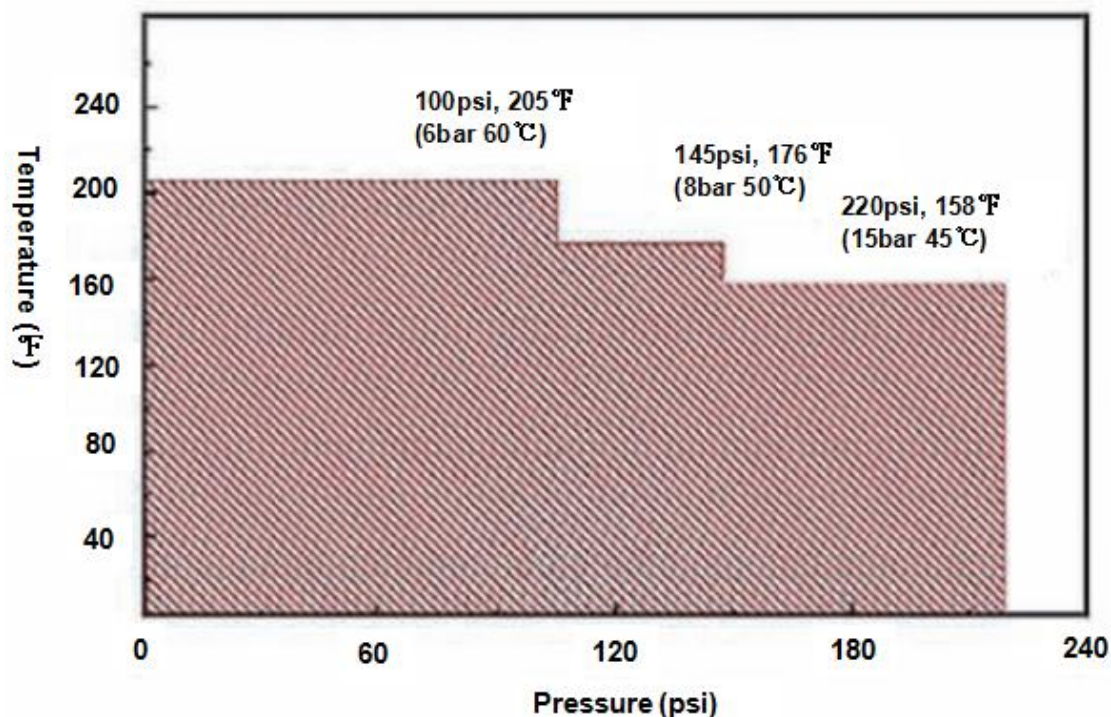

Resistant to strong alkali & acid

Guidelines:

- **Cleaning agent:** the following chemical agents are selected according to feed water's characteristics.
 - 0.1%-5% (weight ratio) NaOH (50°C)
 - 0.2%-1% (weight ratio) Nitric acid and Phosphoric acid (50°C)
 - 0.1%-0.5% (weight ratio) Synthetic detergent KMKLEEN (50°C)
 - 0.5% Anionic surfactant (like SDS: sodium dodecyl sulfate) (50°C)More chemical cleaning agents' usage, please contact with Kaimi R&D center.
 - **Lubricant:** Only using water and glycerin can seal ring be lubricated when assembling and disassembling membrane modules. If using petroleum lubricants or vegetable oil lubricants, modules would be damaged and Kaimi assumes no responsibilities.
 - **Maintenance:**
 - Short term (Two weeks the maximum period): 0.25% (weight ratio) Sodium hydrogen sulfite.
 - Long term: 0.7% (weight ratio) Benzalkonium chloride for system suitability.
- Note: KMTC-S-SD-0412 can't be preserved by concentrated glycerin.
- **Storage:** modules need to be stored wet at all times, which are stored in sealed wet-bags when temperature between 4°C-30°C.

The above data information is real and reliable, but which not means much more quality guaranty from us. Kaimi won't take any responsibilities for any bad data results in membrane application. About more product quality guaranty, please review formal sales provisions and quality guaranty documents.